



Diffuse reflective sensor, Sn=100mm, 4L, 10-30VDC, dark, NPN, PNP, M18, metal, line 2m



Powering Business Worldwide™

Part no. E58-18DP100-HD
Catalog No. 135664
Alternate Catalog No. E58-18DP100-HD

Delivery program

Basic function			Optical sensors
Product range			E58 Harsh Duty Series
For connection of:			2 m connection cable
Design (outer dimensions)		mm	M18 x 1
Rated operational voltage	U_e		10 - 30 V DC
Rated switching distance	S_n	mm	100
Description			with background suppression (Perfect Prox)
Connection			4-wire
Function			Reflected-light beam
Type of light			Visible red
Material			Stainless steel
Switching type			NPN PNP
Switching principle			Dark switching

Information relevant for export to North America

Product Standards UL 508; CSA-C22.2 No. 14; IEC60947-5-2; CE marking

UL File No. E166051

UL Category Control No. NRKH, NRKH7

CSA File No. UL report applies to both Canada and US

CSA Class No. –

North America Certification UL listed, certified by UL for use in Canada

Max. Voltage Rating 30 V DC

Degree of Protection IEC: IP68, IP69K; UL/CSA Type: 1, 2, 3, 3R, 3S, 4, 4x, 6, 6P, 12, 12K, 13

Technical data

General

Standards			IEC/EN 60947-5-2
Ambient temperature			-40 - +55
Mechanical shock resistance		g	100 Shock duration 3 ms
Degree of Protection			IP69

Characteristics

Rated switching distance			
Rated switching distance	S_n	mm	100
Range		mm	0.1
Rated operational voltage	U_e		10 - 30 V DC
Maximum load current	I_e	mA	< PNP: 100 NPN: 250
Response time		ms	1
Switching state display		LED	Red
Protective functions			Short-circuit protective device Protection against polarity reversal Protection against wire breakage
Connection			4-wire
Style			
Design (outer dimensions)		mm	M18 x 1
For connection of:			2 m connection cable

Material		Stainless steel
----------	--	-----------------

Design verification as per IEC/EN 61439

Technical data for design verification		
Operating ambient temperature min.	°C	-40
Operating ambient temperature max.	°C	55

Technical data ETIM 7.0

Sensors (EG000026) / Light scanner with background masking (EC002719)		
Electric engineering, automation, process control engineering / Binary sensor technology, safety-related sensor technology / Optoelectronic sensor / Light scanner w. background masking (ecl@ss10.0.1-27-27-09-04 [AKP253013])		
Adjustment range	mm	0 - 100
Operating distance	mm	0 - 0
Triangulation		Background fade-out
Pre failure notice		No
With time function		No
Rated switching distance	mm	100
Max. switching distance	mm	127
Max. output current	mA	250
Reflector included		No
Analogue output 0 V ... 10 V		No
Analogue output 0 mA ... 20 mA		No
Analogue output 4 mA ... 20 mA		No
Analogue output -10 V ... +10 V		No
With other analogue output		No
Setting procedure		Other
With communication interface analogue		No
With communication interface AS-Interface		No
With communication interface CANOpen		No
With communication interface DeviceNet		No
With communication interface Ethernet		No
With communication interface INTERBUS		No
With communication interface PROFIBUS		No
With communication interface RS-232		No
With communication interface RS-422		No
With communication interface RS-485		No
With communication interface SSD		No
With communication interface SSI		No
Number of semiconductor outputs with signalling function		2
Number of contact energized outputs with signalling function		0
Number of protected semiconductor outputs		0
Number of protected contact energized outputs		0
Type of interface for safety communication		Other
Type of electric connection		Cable
Type of switching output		PNP/NPN
Type of switch function		Other
Operation agent-safety class		Safety class 2
Explosion safety category for gas		None
Explosion safety category for dust		None
Construction type housing		Cylinder, screw-thread
Width sensor	mm	0
Diameter sensor	mm	18
Height of sensor	mm	0
Length of sensor	mm	80
Sensing mode		Dark switching
Material of optical surface		Glass

Material housing		Metal
Max. output current at protected output	mA	0
Min. reflector distance	mm	0
Ambient temperature	°C	-40 - 55
Time of reaction	ms	1
Transmission range of the safety field	m	0
Switching frequency	Hz	500
Type of safety acc. IEC 61496-1		
*Switching voltage of OSSD at state "high"	V	30
Rated control supply voltage Us at AC 50HZ	V	0 - 0
Rated control supply voltage Us at AC 60HZ	V	0 - 0
Rated control supply voltage Us at DC	V	10 - 30
Voltage type		DC
With monitoring function downstream switching devices		No
Laser protection class		None
Wavelength of the sensor	nm	660
Type of light		Other
Light dot	mm ²	0
AWG-number		22
Material of cable sheath		Polyvinyl chloride (PVC)
With restart blockage		No
Suitable for safety functions		No
Degree of protection (IP)		IP67

Approvals

Product Standards		UL 508; CSA-C22.2 No. 14; IEC60947-5-2; CE marking
UL File No.		E166051
UL Category Control No.		NRKH, NRKH7
CSA File No.		UL report applies to both Canada and US
CSA Class No.		-
North America Certification		UL listed, certified by UL for use in Canada
Max. Voltage Rating		30 V DC
Degree of Protection		IEC: IP68, IP69K; UL/CSA Type: 1, 2, 3, 3R, 3S, 4, 4x, 6, 6P, 12, 12K, 13

Dimensions

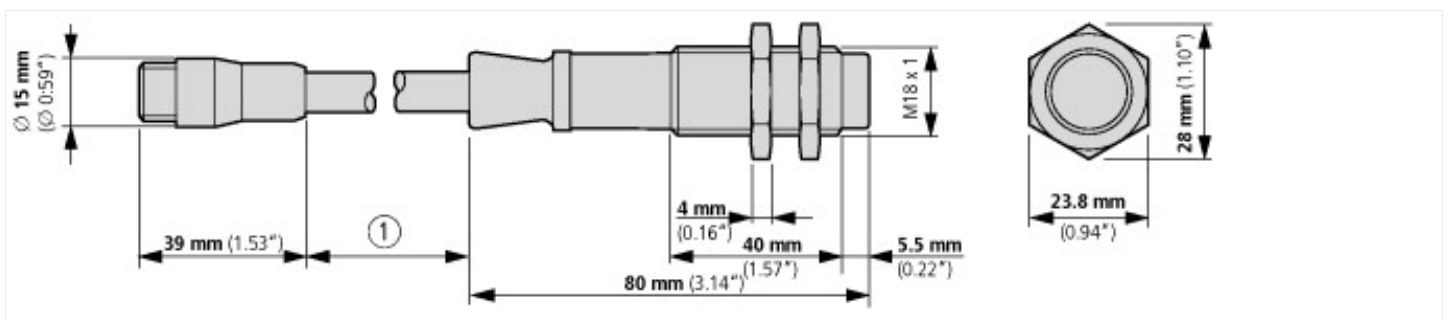

① Connection cable: 2m